

# BAYURSAN CLASS ROYAL C CR Standart VP-LH Boru Tip Kedi Arabası

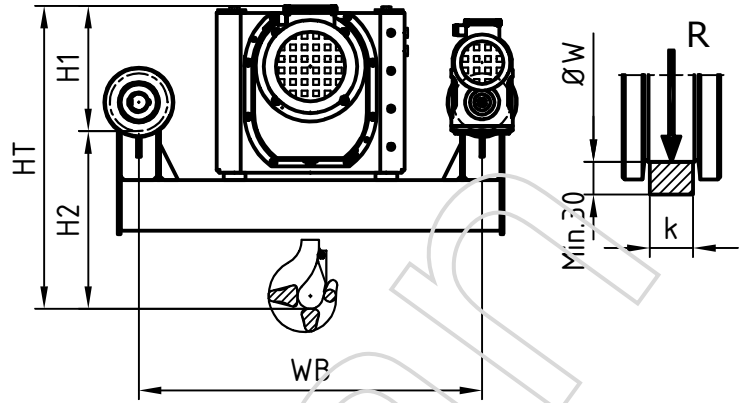
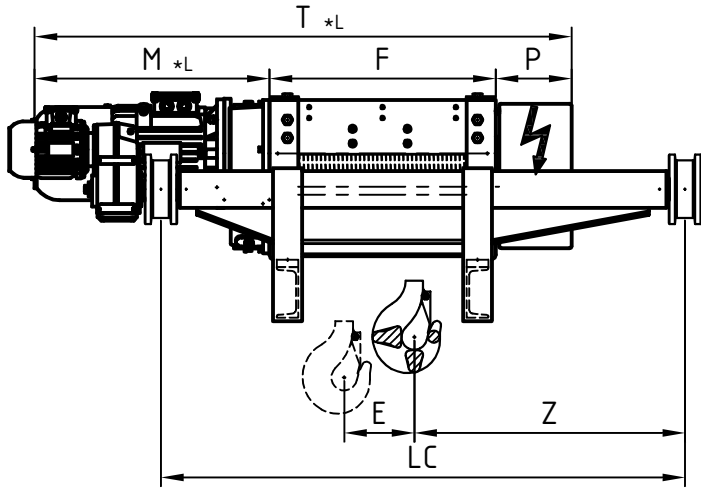

- \* L Büyük Motor
- \* NH Standart Tip Kanca Bloğu
- \* LH Alçak Tavan Kanca Bloğu

Halat Donanımı	Kaldırma Ünitesi	Kaldırma Yüksekliği	Tüm ölçüler milimetredir.														
			LC	WB	DW	k	H1	H2	HT	Z	E	T	M	F	P		
2/1	CR2 L1	≤ 7,5	1300	950	160	40	347	603	950	671,5	144	1366	650	506	210		
	CR2 L2	≤ 10	1450							701,5	204	1486		626			
	CR2 L3	≤ 15	1650							691,5	306	1696		836			
	CR2 L4	≤ 20	1850							681,5	414	1906		1046			
	CR3 L1	≤ 7,5	1550	1000	160	40	430	617	1092	798,5	192	1622	786	626	210		
	CR3 L2	≤ 10	1650							802,5	240	1718		722			
	CR3 L3	≤ 15	1900							796,5	368	1974		978			
	CR3 L4	≤ 20	2150							822,5	480	2198		1202			
	CR3 L5	≤ 25	2350							798,5	592	2422		1426			
	CR4 L1	≤ 7,5	1700	1100	200	40	484	849	1333	909	189	1715	873	632	210		
	CR4 L2	≤ 10	1800							901	243	1823		740			
	CR4 L3	≤ 15	2000							885	351	2039		956			
CR4 L4	≤ 20	2200	887							450	2237	1154					
CR4 L5	≤ 25	2400	871							558	2453	1370					
4/1	CR2 L1	≤ 3,75	1300	950	160	40	347	NH	NH	719	72	1366	650	506	210		
	CR2 L2	≤ 5	1450							594	102	1486		626			
	CR2 L3	≤ 7,5	1650							539	153	1696		836			
	CR2 L4	≤ 10	1850							LH	LH	729		207		1906	1046
	CR3 L1	≤ 3,75	1550	1000	160	40	430	NH	NH	849	96	1622	786	626	210		
	CR3 L2	≤ 5	1650							645	120	1718		722			
	CR3 L3	≤ 7,5	1900							847	184	1974		978			
	CR3 L4	≤ 10	2150							595	240	2198		1202			
	CR3 L5	≤ 12,5	2350							LH	LH	849		296		2422	1426
	CR4 L1	≤ 3,75	1700	1100	200	40	484	NH	NH	976,5	94,5	1715	873	632	210		
	CR4 L2	≤ 5	1800							872	1356	968,5		121,5		1823	740
	CR4 L3	≤ 7,5	2000							812	1296	952,5		175,5		2039	956
CR4 L4	≤ 10	2200	LH							LH	954,5	225		2237		1154	
CR4 L5	≤ 12,5	2400	938,5							279	2453	1370					
6/1	CR3 L3	≤ 5	1900	1100	200	40	430	783	1213	948	123	1974	786	978	210		
	CR3 L4	≤ 6,67	2150							974	160	2198		1202			
	CR3 L5	≤ 8,33	2350							950	197	2422		1426			
	CR4 L3	≤ 5	2000	1100	250	50	483	1000	1483	1093	117	2039	873	956	210		
	CR4 L4	≤ 6,67	2200							1095	150	2237		1154			
CR4 L5	≤ 8,33	2400							1079	186	2453		1370				